

Wireless Sensor Adapter



General Description

The wireless sensor adapter allows long range wireless sensors to communicate with local or online wireless sensor monitoring systems by connecting to a PC or 3rd party IoT gateways via USB connection.

Easy plug & play support for PC use. If the PC has an active internet connection and you wish to use it with the ICARE online software, install the free ICARE Gateway application to pass sensor data to the online system. If you wish to use your wireless sensors locally (collect and store sensor data on your PC), purchase and install the ICARE Express standalone software and all sensor data will be stored within the standalone software's database. The ICARE Express software allows you to export sensor data in a .csv format spreadsheet, and is also capable of sending SMS text and email alerts if the host computer has an active Internet connection.

With the online monitoring software, you can easily configure your network, view collected sensor data and set alarms through SMS or e-mail, all from any web enabled browser. The system allows for complete configuration and customization at a sensor, local network, or client wide level.

The wireless sensor adapter is specifically designed to respond to the increasing market need for global technology that accommodates a variety of vertical M2M application segments and remote wireless sensor management solutions. With support for several leading 3rd party IoT gateways, it is easy to integrate long range wireless sensors with existing IoT platforms.

Enjoy reliable, low cost, wireless monitoring of your facilities or specific applications, with ICARE wireless sensor networks.

Wireless Sensor Adapter Features

- Wireless range of 1,000+ feet through 12-14 walls *
- 900 MHz Frequency Hopping Spread Spectrum (FHSS) 868 and 433 MHz Frequency Agile
- Improved interference immunity
- Security (Diffie-Hellman Key Exchange + AES-128 CBC for sensor data messages)
- 16,000 sensor message memory
- Over the air updates (future proof)
- Optional RS232 DB9 communication port
- USB, RS232, or external power options
- Uses standard FTDI driver so no driver installation required
- External USB cable allows gateway to be positioned for improved communication range
- Programmable heart-beat control
- Supports up to 100 wireless sensors per USB
- Windows 10, 8, 7, and Vista compatible

* Actual range may vary depending on environment.

Wireless Range Comparison

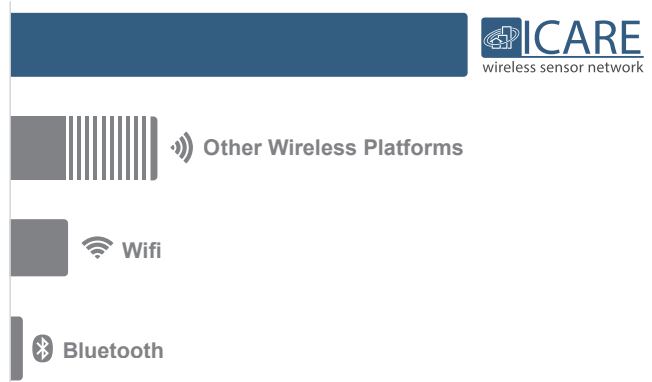

Wireless Sensor Adapter Dimensions

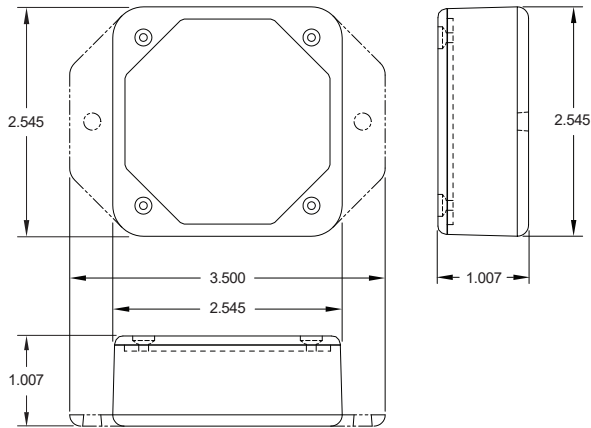

Example Applications

- Facilities / Building Operations
- Restaurants / Food Service
- Server Rooms / Data Closets
- Pharmaceutical / Labs
- Heating and Cooling
- Agriculture Monitoring
- And many more...

Wireless Sensor Adapter Specifications

USB

Type:	USB 2.0 Full Speed Bus Standard
Display Name:	USB Radio Gateway
Display Type:	ApnClass
Software Version:	3.4.0.2 or later
Software Compatible Platforms:	Microsoft Windows 10, 8, 7 or Vista required. (Windows XP and older are not supported.)
Bus Reported Device Description:	M+ LINK
Memory Capacity:	14,336 up messages (to gateway/server) 2,048 down messages (to sensors)
RS232 (Optional)	115200 baudrate, 8 data bits, no parity, 1 stop bit, DB9 connector

Power

Power	Powered through USB output of PC (Optional) External Power (Optional) RS232 Power Pin 4 (Optional) RS232 Power Pin 8
Maximum Power Required:	100 mA

Mechanical

Enclosure	ABS plastic
Dimensions	3.5 in. x 2.545 in. x 1.007 in.
Weight	4 ounces

Environmental

Operating Temperature	-40°C to +85°C
-----------------------	----------------

Wireless

Wireless Range	1,000+ ft. non-line-of-sight ***
Security	256-bit key exchange and AES-128 CTR
Certifications	900 MHz product; FCC ID: ZTL- G2SC1 and IC: 9794A-G2SC1



* Hardware cannot withstand negative voltage. Please take care when connecting a power device.

** At temperatures above 100°C, it is possible for the board circuitry to lose programmed memory.

*** Actual range may vary depending on environment.

Caution / Notice:

ICARE commercial grade products are designed for applications in ordinary environments (normal room temperature, humidity and atmospheric pressure). Do not use these sensors under the following conditions as these factors can deteriorate the product characteristics and cause failures and burn-out.

- Corrosive gas or deoxidizing gas - chlorine gas, hydrogen sulfide gas, ammonia gas, sulfuric acid gas, nitric oxides gas, etc.)
- Volatile or flammable gas
- Dusty conditions
- Under low or high pressure
- Wet or excessively humid locations
- Places with salt water, oils chemical liquids or organic solvents
- Where there are excessively strong vibrations
- Other places where similar hazardous conditions exist

Use these product within the specified temperature range. Higher temperature may cause deterioration of the characteristics or the material quality of this product.



For more information about our products or to place an order, please contact our sales department at 586-899-1150.

Visit us on the web at www.icaremonitoring.com.

ICARE Monitoring
Saint Clair Shores, MI 48082
586-899-1150
www.icaremonitoring.com